

# CL Technical Data



# CL Technical Data

VDI 2198

Specification	1.2	Model		CL 10,5 MONO	CL 12 MONO	CL 10,5 SX	CL12 SX	CL 10,5 DX	CL 12 DX
	1.3	Drive unit		Electric		Electric		Electric	
	1.4	Drive control type		Tiller		Tiller		Tiller	
	1.5	Loading capacity	Q (t)	1,05	1,2	1,05	1,2	1,05	1,2
	1.6	Load center	c (mm)	600		600		600	
	1.8	Distance between fork face to load wheel axle	x (mm)	776		756		756	
	1.9	Distance between wheels centres	y (mm)	1298		1298		1298	
Weights	2.1	Truck weight (without battery)	Kg	623		743 <sup>(3)</sup>		755 <sup>(3)</sup>	
	2.2	Axle loadings laden (front/rear)	Kg	718 / 1106 <sup>(1)</sup>	770 / 1244 <sup>(2)</sup>	782 / 1163 <sup>(4)</sup>	832 / 1302 <sup>(5)</sup>	790 / 1167 <sup>(4)</sup>	840 / 1306 <sup>(5)</sup>
	2.3	Axle loading unladen	Kg	577 / 198	608 / 205 <sup>(2)</sup>	656 / 239 <sup>(4)</sup>	688 / 246 <sup>(5)</sup>	664 / 243 <sup>(4)</sup>	696 / 250 <sup>(5)</sup>
Wheels and Tyres	3.1	Tyre type		Polyurethane		Polyurethane		Polyurethane	
	3.2	Front tyre dimensions	(mm)	230 / 120		230 / 120		230 / 120	
	3.3	Rear tyre dimensions	(mm)	85X90		85X90		85X90	
	3.5	Wheels quantity front/rear (x= traction)		1x-1 / 2		1x-1 / 2		1x-1 / 2	
	3.6	Distance between traction and pivoting wheel's axles	b10 (mm)	505		505		505	
	3.7	Distance between load wheels centres	b11 (mm)	397		397		397	
Dimensions and Overall Sizes	4.2	Closed height	h1 (mm)	2300		2000 / 2350		1953 / 2303	
	4.3	Full free lift	h2 (mm)	1789		120		1443 / 1793	
	4.4	Lift height	h3 (mm)	1800		2900 / 3600		2900 / 3600	
	4.5	Extended height	h4 (mm)	2310 <sup>(9)</sup>		3410 / 4110 <sup>(9)</sup>		3410 / 4110 <sup>(9)</sup>	
	4.6	Partial free lift	h5 (mm)	/		/		/	
	4.9	Travel position tiller height (min/max)	h14 (mm)	762 / 1232		762/1232		762/1232	
	4.15	Forks clearance from the ground	h13 (mm)	85		85		85	
	4.19	Total length	l1 (mm)	1850		1869		1869	
	4.20	Length to fork face	l2 (mm)	700		719		719	
	4.21	Total width	b1 (mm)	790		790		790	
	4.22	Fork dimensions	s/e/l (mm)	56 / 175 / 1150		56 / 175 / 1150		56 / 175 / 1150	
	4.24	Mast width	b3 (mm)	660		660		660	
	4.25	Maximum forks width	b5 (mm)	570		570		570	
	4.32	Clearance off ground	m2 (mm)	29		29		29	
	4.33	Aisle width for 1000x1200 pallet 1200 forking side	Ast3 (mm)	2430 <sup>(10)</sup>		2438 <sup>(10)</sup>		2438 <sup>(10)</sup>	
4.34	Aisle width for 800x1200 pallet 800 forking side	Ast3 (mm)	2373 <sup>(10)</sup>		2388 <sup>(10)</sup>		2388 <sup>(10)</sup>		
4.35	Turning radius	Wa (mm)	1590 <sup>(10)</sup>		1590 <sup>(10)</sup>		1590 <sup>(10)</sup>		
Performance	5.1	Traction speed (laden /unladen )	km/h	5,6/6		5,6/6	5,5/6	5,6/6	5,5/6
	5.2	Lifting speed (laden/unladen)	m/s	0,13 / 0,18	0,12 / 0,18	0,13 / 0,21 <sup>(3)</sup>	0,17 / 0,3 <sup>(3)</sup>	0,15 / 0,27 <sup>(3)</sup>	0,13 / 0,27 <sup>(3)</sup>
	5.3	Lowering speed (laden/unladen)	m/s	0,28 / 0,22	0,29 / 0,22	0,31 / 0,31 <sup>(3)</sup>	0,32 / 0,31 <sup>(3)</sup>	0,30 / 0,24 <sup>(3)</sup>	0,31 / 0,24 <sup>(3)</sup>
	5.7	Gradeability KB30' (laden/unladen)	%	1,7 / 8,0	1,2 / 7,5	1,3 / 6,5	1,0 / 6,1	1,3 / 6,5	1,0 / 6,1
	5.8	Maximum gradeability KB5' (laden/unladen)	%	6,7 / 9,0 <sup>(11)</sup>	5,8 / 9,0 <sup>(11)</sup>	6,1 / 9,0 <sup>(11)</sup>	5,3 / 9,0 <sup>(11)</sup>	6,1 / 9,0 <sup>(11)</sup>	5,3 / 9,0 <sup>(11)</sup>
	5.10	Service brake		Electric at butterfly release		Electric at butterfly release		Electric at butterfly release	
Engine	6.1	Traction motor, performance KB 60'	kW	1		1		1	
	6.2	Lift Motor, performance 15% ED	kW	2,2		2,2		3	
	6.3	Battery to British Standard / DIN 43531/35/36 A, B, C		British Standard		British Standard		British Standard	
	6.4	Volts/ampere	V / Ah	24/140 (200-300)	24/200 (300)	24/140 (200-300)	24/200 (300)	24/140 (200-300)	24/200 (300)
	6.5	Battery weight (+-5%)	Kg	152 (191-250)	191 (250)	152 (191-250)	191 (250)	152 (191-250)	191 (250)
Others	8.1	Control unit type		Electronic		Electronic		Electronic	
	8.4	Noise level at operator position	dB (A)	<70		<70		<70	

The values presented are to be taken as indicative and not binding; they refer to the standard equipment

- 1) With 24V/140 Ah battery
- 2) With 24V/200 Ah battery
- 3) With h3 = 3600 mm mast
- 4) With 24V/140 Ah battery and h3 = 3600 mm mast
- 5) With 24V/200 Ah battery and h3 = 3600 mm mast
- 6) With h3 = 4305 mast
- 7) With 24V/140 Ah battery and h3 = 4305 mm mast

- 8) With 24V/200 Ah battery and h3 = 4305 mm mast
- 9) With load back rest +502 mm
- 10) With tiller active in vertical position -45 mm
- 11) Linked to truck configuration

CL 10,5 TX	CL 12 TX
Electric	
Tiller	
1,05	1,2
600	
737	
1298	
809 <sup>(6)</sup>	
807 / 1204 <sup>(7)</sup>	854 / 1346 <sup>(8)</sup>
697 / 264 <sup>(7)</sup>	728 / 272 <sup>(8)</sup>
Polyurethane	
230 / 120	
85X90	
1x-1 / 2	
505	
397	
1870 / 1938	
1360 / 1428	
4100 / 4305	
4610 / 4815 <sup>(9)</sup>	
/	
762/1232	
85	
1889	
738	
790	
56 / 175 / 1150	
660	
570	
29	
2445 <sup>(10)</sup>	
2402 <sup>(10)</sup>	
1590 <sup>(10)</sup>	
5,6 / 6	5,5 / 6
0,18 / 0,28 <sup>(6)</sup>	0,16 / 0,28 <sup>(6)</sup>
0,30 / 0,24 <sup>(6)</sup>	0,31 / 0,24 <sup>(6)</sup>
1,2 / 5,8	0,9 / 5,4
5,8 / 8,9 <sup>(11)</sup>	5,0 / 9,0 <sup>(11)</sup>
Electric at butterfly release	
1	
3	
British Standard	
24/140 (200-300)	24/200 (300)
152 (191-250)	191 (250)
Electronic	
<70	

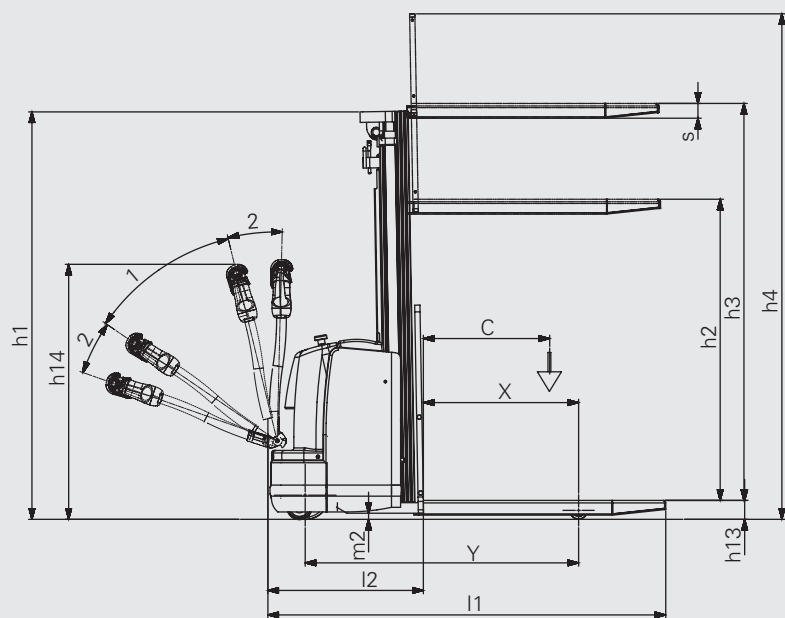

1= Travel  
2= Bracking

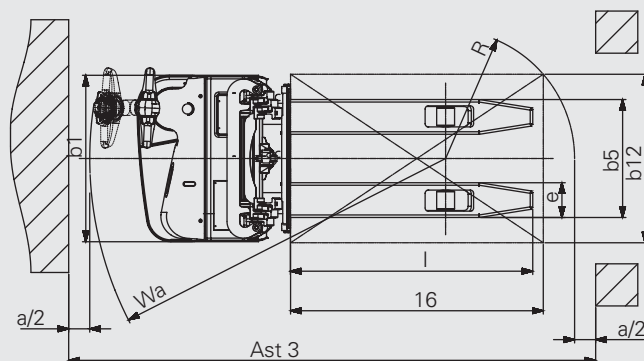

CL 10,5				Mono	Simplex	Duplex	Simplex	Duplex	Triplex	Triplex
Mast type										
Lifting height	$h_3$	mm		1800	2900	2900	3600	3600	4100	4305
Lifting height from floor	$h_3+h_{13}$	mm		1885	2985	2985	3695	3685	4185	4390
Lowered height	$h_1$	mm		2300	2000	1950	2350	2300	1866	1935
Extended height	$h_4$	mm		2310	3410	3410	4110	4110	4610	4815
Standard free lift	$h_2$	mm		1785	120	1450	120	1800	1367	1435
Residual capacity at maximum height with 140 Ah battery (minimum weight 154 Kg)	Q	kg		1050	1050	1050	950	950	850	800

CL 12				Mono	Simplex	Duplex	Simplex	Duplex	Triplex	Triplex
Mast type										
Lifting height	$h_3$	mm		1800	2900	2900	3600	3600	4100	4305
Lifting height from floor	$h_3+h_{13}$	mm		1885	2985	2985	3695	3685	4185	4390
Lowered height	$h_1$	mm		2300	2000	1950	2350	2300	1866	1935
Extended height	$h_4$	mm		2310	3410	3410	4110	4110	4610	4815
Standard free lift	$h_2$	mm		1785	120	1450	120	1800	1367	1435
Residual capacity at maximum height with 200 Ah battery (minimum weight 192 Kg)	Q	kg		1200	1200	1200	1050	1050	900	850

## CL High lift stacker



The new stacker CL is introduced as an essential work tool for handling of pallets, cases and container cages in small to medium duty logistic applications. The diversity of applications within warehouses logistics expands the application range of the stacker: It can be found in small stores as well as specific applications for handling in production areas, stocking, goods in and out bays.

**The design:** The totally new design keeps the existing, well tested, four point configuration and side mounted tiller. The motor compartment and battery covers are made of high impact resistant polyethylene, well integrated in the design with smooth contours.

**Chassis:** The four point design and sidemounted tiller previously mentioned ensure a high degree of stability and perfect visibility during loading and unloading operations. The traction group and pivoting wheel are completely enclosed within the chassis dimensions ensuring operator foot protection.

A standard chassis, made of steel welded onto the main structure is adopted throughout the range. Various mast configurations may be combined with the chassis. Nominal capacities of 1050 kg and 1200 kg are available.

**Traction group:** Electronic control of traction allows energy recuperation when releasing the butterfly. The 1 kw traction motor is of the separate field - excitation type. The pivoting wheel is easily adjusted maintaining perfect contact with floor and maximum stability.

**Lift group:** Simplex, duplex and triplex high visibility masts with partial or full free lift are fitted on both capacity trucks. Two dedicated lift motors are available, 2.2 kw & 3 kw, according to capacity and lift height.

**Tiller:** The new tiller head allows control of all the lift functions through ergonomically placed buttons to give maximum comfort levels to the operator. Mechanical operation microswitches have been replaced by push type buttons.

**Electronic control:** The stacker is equipped with a unique electronic control for both traction and lift. The use of digital transmission of electrical signals has reduced considerably the volume of cables. The adoption of automotive type connectors and proximity switches instead of mechanical micro switches and the reduction of contactors have consistently increased reliability.

### Optional equipment:

- Cold store spec. ■ Down to -30 degrees C° ■ Tandem load wheels. ■ Rubber traction wheel.
- Proportional electrovalve control for hydraulic functions. ■ DC-DC converter
- Tempered glass mast shield ■ Load backrest ■ Incline option ■ Braking cylinders ■ Battery trolley.

Technical data are given as an indication.

OM Carrelli Elevatori reserves the right to modify them without notice.



OM Carrelli Elevatori S.p.A.  
Viale A. De Gasperi, 7  
I-20020 Lainate (MI)  
Tel.: +39(02)937 65-1  
Fax: +39(02)937 65-450  
[www.om-mh.com](http://www.om-mh.com)