

CSR Technical Data



CSR Technical Data

VDI 2198

Specification				OM PIMESPO	OM PIMESPO	OM PIMESPO	
1.1	Manufacturer						
1.2	Manufacturer type designation			CSR 12,5	CSR 16	CSR 20	
1.3	Drive unit: electric (battery or mains), diesel, petrol, fuel gas			Electric	Electric	Electric	
1.4	Operator type: hand, pedestrian, standing, seated, order-picker			Seated	Seated	Seated	
1.5	Load capacity	Q (Kg)		1,25	1,6	2	
1.6	Load center	c (mm)		600 ⁽¹³⁾	600 ⁽¹³⁾	600 ⁽¹³⁾	
1.8	Load distance, centre of drive axle to fork face	x (mm)		690 ⁽¹⁾	690 ⁽¹⁾	680 ⁽¹⁾	
1.9	Wheelbase	y (mm)		1534 ⁽¹⁾	1534 ⁽¹⁾	1534 ⁽¹⁾	
Weights	2.1	Truck weight (without battery)		kg	1120 ⁽²⁾	1240 ⁽²⁾	1470 ⁽²⁾
	2.2	Axle loading, loaded	(front/ rear)	kg	-	-	-
	2.3	Axle loading, unloaded	(front/ rear)	kg	-	-	-
Wheels and Tyres	3.1	Tyres: solid rubber, superelastich, pneumatic, polyurethane			Vulkollan	Vulkollan	Vulkollan
	3.2	Tyre size (drive side)	driven wheel / Swivel castor wheel	mm	Ø300 x 100 / Ø200 x 50	Ø300 x 100 / Ø200 x 50	Ø300 x 100 / Ø200 x 50
	3.3	Tyre size (Load side)		mm	Ø85 x 86,5 ⁽³⁾	Ø85 x 86,5 ⁽³⁾	Ø85 x 86,5 ⁽³⁾
	3.5	Wheels number:	drive side / load side (x= driven wheel)		1x-3 / 4	1x-3 / 4	1x-3 / 4
	3.6	Tread, front	(drive side)	b10 (mm)	605	605	605
	3.7	Tread, rear	(load side)	b11 (mm)	380	380	380
	Dimensions and Overall Sizes	4.2	Height, mast lowered		h1 (mm)	2150	2150
4.3		Free lift		h2 (mm)	150	150	240
4.4		Lift height		h3 (mm)	3250	3250	3380
4.5		Height, mast extended		h4 (mm)	3722 ⁽¹²⁾	3802 ⁽¹²⁾	4005 ⁽¹²⁾
4.6		Initial lift		h5 (mm)	115	115	115
4.7		Height of driver's overhead guard		h6 (mm)	2150	2150	2150
4.8		Height of seat		h7 (mm)	1080	1080	1080
4.15		Forks height, lowered		h13 (mm)	86	86	91 ⁽⁴⁾
4.19		Overall length		l1 (mm)	2214 ⁽⁵⁾	2214 ⁽⁵⁾	2224 ⁽⁵⁾
4.20		Length to face of forks		l2 (mm)	1094	1094	1104
4.21		Overall width		b1 (mm)	980	980	980
4.22		Fork dimensions		s/e/l (mm)	56 / 184 / 1120 ⁽⁶⁾	64 / 184 / 1120 ⁽⁶⁾	91 / 210 / 1120 ⁽⁶⁾
4.24		Fork carriage width		b3 (mm)	680	680	700
4.25		Maximum forks width		b5 (mm)	564 ⁽⁷⁾	564 ⁽⁷⁾	580 ⁽⁸⁾
Performance		4.31	Ground clearance, laden, below mast		m1 (mm)	30	30
	4.32	Ground clearance, centre of wheelbase		m2 (mm)	30 ⁽⁹⁾	24 ⁽⁹⁾	25 ⁽⁹⁾
	4.33	Aisle width for pallets 1000x1200 crossways (1200 forking side)		Ast (mm)	2691 ⁽¹⁰⁾	2691 ⁽¹⁰⁾	2691 ⁽¹⁰⁾
	4.34	Aisle width pallets 800x1200 lengthways (800 forking side)		Ast (mm)	2664 ⁽¹¹⁾	2664 ⁽¹¹⁾	2664 ⁽¹¹⁾
	4.35	Turning radius		Wa (mm)	1815	1815	1815
	5.1	Travel speed:	Loaded / unloaded	km/h	7 / 8	6,7 / 8	6,5 / 8
	5.2	Lift speed:	Loaded / unloaded	m/s	0,16 / 0,27	0,14 / 0,27	0,10 / 0,15
	5.3	Lowering speed:	Loaded / unloaded	m/s	-	-	-
	5.7	Gradeability KB 30':	Loaded / unloaded	%	6 / 6	6 / 6	6 / 6
	5.8	Max gradeability KB 5':	Loaded / unloaded	%	6 / 6	6 / 6	6 / 6
5.10	Brakes			Mechanical / hydraulic	Mechanical / hydraulic	Mechanical / hydraulic	
Engine	6.1	Drive motor rating S2 60min		kW	2,8	2,8	2,8
	6.2	Lift motor rating at S3 15%		kW	3,0	3,0	3,0
	6.3	Battery according to British Standard / IEC 254-; A, B, C			IEC 254-2; A	IEC 254-2; A	IEC 254-2; A
	6.4	Battery voltage / nominal capacity k5		V / Ah	24 / 600-775 (500 - 625)	24 / 600-775 (500 - 625)	24 / 600-775 (500 - 625)
	6.5	Battery weight (± 5%)		kg	590 (435)	590 (435)	590 (435)
Others	8.1	Control unit type			Electronic	Electronic	Electronic
	8.4	Sound level at the driver's ear according to DIN 12 053		dB (A)	-	-	-

The values presented are to be taken as indicative and not binding; they refer to the standard equipment

(1) With Duplex mast (with Triplex mast = 1694mm)
 (2) With smallest closed height mast (with initial lift add 80 Kg)
 (3) With initial lift: Ø85 x 60mm
 (4) Initial lift version 87mm
 (5) With fork length l = 1120mm
 (6) Fork length available as option l=900mm
 (7) Initial lift version b5 = 664mm
 (8) Initial lift version b5 = 630mm

(9) With initial lift add 115mm
 (10) Calculated in accordance with VDI 3597 Ast = 2325mm (fork l=900mm)
 (11) Calculated in accordance with VDI 3597 Ast = 2525mm
 (12) With load back rest 800mm h4 + 413mm
 With load back rest 1000mm h4 + 613mm
 (13) Load center C = 500 with fork length l = 900

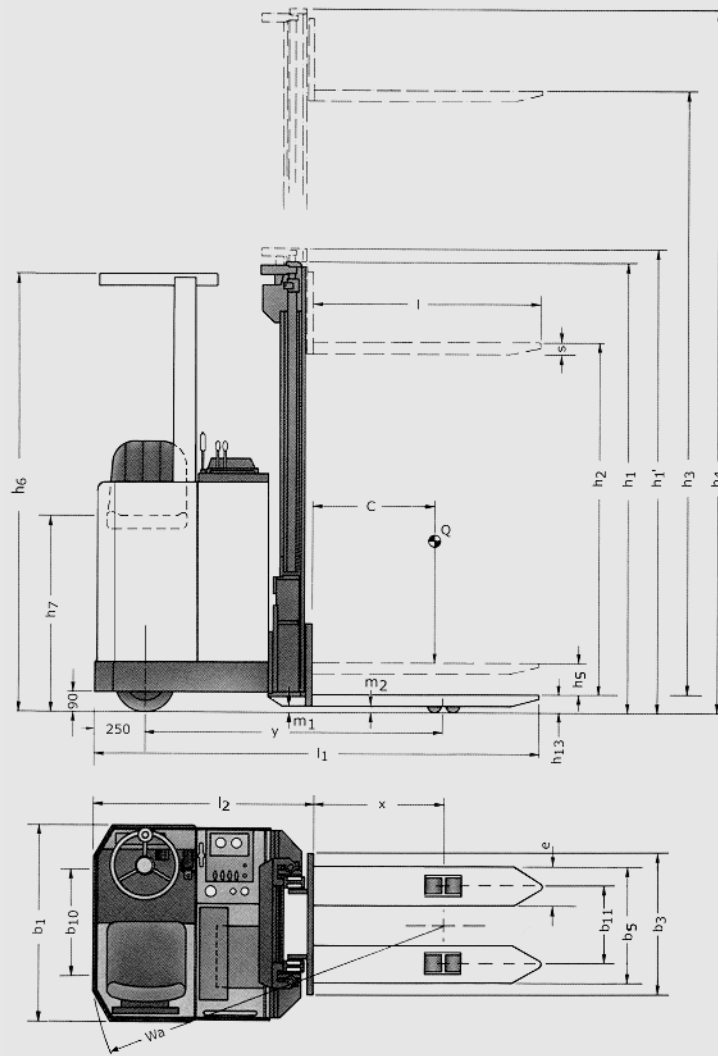

CHARACTERISTICS OF ALTERNATIVE LIFTS

			Simplex	Duplex		Triplex			
1.25 t Mast type	Lifting height	h_3 mm	3250	3750	3250	3750	3925	4375	5275
	Height, minimum dimension	h_1 mm	2150	2400	2090	2340	1830	1980	2280
	Height, maximum dimension	h_4 mm	3722	4222	3722	4222	4472	4922	5822
	Free lift	h_2 mm	150	150	1618	1868	1283	1433	1733
1.6 t Mast type	Lifting height	h_3 mm	3250	3750	3250	3750	3925	4375	5275
	Height, minimum dimension	h_1 mm	2150	2400	2090	2340	1830	1980	2280
	Height, maximum dimension	h_4 mm	3802	4302	3802	4302	4472	4922	5822
	Free lift	h_2 mm	150	150	1648	1868	1283	1433	1733
2.0 t Mast type	Lifting height	h_3 mm	3380	-	-	-	3720	4170	4920
	Height, minimum dimension	h_1 mm	2280	-	-	-	1830	1980	2230
	Height, maximum dimension	h_4 mm	4005	-	-	-	4345	4795	5545
	Free lift	h_2 mm							

CSR

Electric Sideways Seated Ride-on Stacker



Chassis: Robust steel construction consisting of the traction unit, which accommodates the driver's seat and all the controls, and the lift unit. Easy access to the motor and battery compartments. The battery is not lifted with the forks, resulting in greater energy savings.

4-wheel structure: Optimum weight distribution and reduced ground pressure, important features when using a goods lift.

Driver's seat: Spacious driver's seat designed to reduce operator fatigue. Hydraulically cushioned seat that can be adjusted in accordance with the driver's weight. Padded armrest with document holder. All the controls are located on the multi-function handle. The travel direction lever, the load lift/lower buttons and the horn can all be operated without the operator having to move his/her arm.

Steering: Power steering with a steering wheel with spinner knob, universal joint connection and chain transmission. 95° steering in both directions. The steering motor speed is electronically controlled by a sensor on the universal joint that checks the rotations of the reducer; the electric motor operates only when necessary. The truck starts only if the operator ride-on pedal is depressed. The series excited motor with forced air ventilation is firmly fixed to the frame, preventing the wiring from becoming twisted. High performance levels and optimal energy consumption due to the bevel gear transmission.

Hydraulic system: High pressure pump unit operated by an internal motor. Safer working conditions due to the simple lift and lower operation. The pressure relief and lower function adjustment valves protect the system against overloads.

Initial arm lift: Increased clearance between the arms and the ground to facilitate handling on uneven ground.

Masts: Telescopic masts with or without free lift offer ample visibility.

Tandem load rollers: Support Arms equipped with tandem load rollers that, together with the initial arm lift function, facilitate handling on uneven floors.

Braking: Pedal service brake and parking handbrake. The brake with internal brake shoes and asbestos-free brake lining acts on the drive shaft and serves as the service brake and parking brake. The machine brakes smoothly and gradually when reversing.

Battery indicator: Battery level indicator and hour meter.

Battery: Hinged cover provides easy access for maintenance operations. The battery can be removed with a battery stand if the truck is for multi shift use.

Safety: All OM trucks comply with the Direttiva Macchine 98/37/CEE and are CE certified. OM is certified to ISO 9001 standards.

Additional equipment Initial arm lift. Power steering with inverted rotation of the lift block reducer

Technical data are given as an indication.

OM Carrelli Elevatori reserves the right to modify them without notice.



OM Carrelli Elevatori S.p.A.
Viale A. De Gasperi, 7
I-20020 Lainate (MI)
Tel.: +39(02)937 65-1
Fax: +39(02)937 65-450
www.om-mh.com