

TSR - TLR Technical Data



TSR-TLR Technical Data

VDI 2198

Specification			OM PIMESPO	OM PIMESPO		
1.1	Manufacturer		OM PIMESPO	OM PIMESPO		
1.2	Model designation		TSR 30	TLR 20		
1.3	Power: (electric,diesel,petrol)		Electric	Electric		
1.4	Operator type: hand, pedestrian, standing, seated, order-picker.		Standing / rider seated	Standing / rider seated		
1.5	Load capacity	Q (t)	3	2		
1.6	Load centre distance	c (mm)	600 ⁽¹⁾	600 ⁽¹⁾		
1.8	Load distance, lowered / raised	x (mm)	935 / 775 ⁽¹⁾	969 / 904		
1.9	Wheelbase, lowered / raised	y (mm)	1898 / 1738 ⁽¹⁾	1623 / 1558		
Weights	2.1	Weight (battery included)	kg	2040 ⁽¹⁾	1070 ⁽¹⁾	
	2.2	Axle loading with load	driver side / load side	kg	2595 / 2445 ⁽¹⁾	1450 / 1620 ⁽¹⁾
	2.3	Axle loading without load	driver side / load side	kg	1525 / 515 ⁽¹⁾	820 / 250 ⁽¹⁾
Wheels and Tyres	3.1	Tyres: solid rubber, Polyurethane.		Vulkollan	Vulkollan / (only drive wheel in Solid Rubber) ⁽²⁾	
	3.2	Tyre size driver side	Drive wheel / Swivel castor wheel	mm	∅ 300 X 100 / ∅ 200 X 50	∅ 250 X 80 / ∅ 125 X 50
	3.3	Tyre size load side		mm	∅ 85 X 86,5	∅ 85 X 100 ⁽⁶⁾
	3.5	Wheels number	load side/driver side (x=drive wheel)		4 / 1x-3	2 ⁽⁷⁾ / 1x-2
	3.6	Tread	driver side	b10 (mm)	604	507
	3.7	Tread	load side	b11 (mm)	380	350 ⁽¹⁾ - (500) ⁽³⁾
	4.4	Lift height		h3 (mm)	115	120
Dimensions and Overall Sizes	4.8			h7 (mm)	1080	-
	4.9	Height max of steering wheel		h14 (mm)	-	1345
	4.15	height lowered		h13 (mm)	85	85
	4.19	Overall length		1 (mm)	2330 ⁽¹⁾	1970 ⁽¹⁾
	4.20	Length to front face of forks		2 (mm)	1210	820
	4.21	Overall width		b1 (mm)	980	796
	4.22	Fork dimensions		s/e/l (mm)	56 / 200 / 1120 ⁽²⁾	52 / 170 / 1150 ⁽⁴⁾
	4.25	Outside fork width dimension		b5 (mm)	570	520 - (670)
	4.32	Ground clearance centre of wheelbase		m2 (mm)	22	33
	4.33	Aisle width pallets 1000 x 1200 crossways (1200 forking side)		Ast (mm)	2440 ⁽³⁾	2026 ⁽⁵⁾
	4.34	Aisle width pallets 800 x 1200 lengthwise (800 forking side)		Ast (mm)	2645	2226
4.35	turning radius		Wa (mm)	2175	1795	
Performance	5.1	Travel speed	with load / without load	km/h	9,0 / 12,0	8 / 11
	5.2	Lift speed	with load / without load	m/s	0,046 / 0,064	0,075 / 0,109
	5.3	Lowering speed	with load / without load	m/s	0,052 / 0,041	0,05 / 0,040
	5.7	Gradeability	(with load / without load) ⁽¹⁾	%	6 / 15	-
	5.8	Max. Gradeability	(with load / without load) ⁽¹⁾	%	-	8 / 12
Engine	5.9	Acceleration time	(with load / without load)	s	6,2 / 5,0	6,34 / 4,80
	5.10	service brake			hydraulic / mechanics	Electric
	6.1	Drive motor, S2 60 minute rating		kW	4,2	2,0
	6.2	Lifting motor, S3 15% rating		kW	2,0	2,0
Others	6.3	Battery DIN IEC 254-2; A, B, C, no			IEC 254-2; A	IEC 254-2; A
	6.4	Battery voltage / capacity at 5 hour rate		V / Ah	48 / 620	24 / 420
	6.5	Battery weight (± 5%)		Kg	940	370
	6.6	Energy consumption according to VDI cycle		Kwh/h	-	0,8
	8.1	Drive control			Electronic	Electronic
	8.4	Sound level at the driver's ear according to DIN 12053		dB (A)	68,9	< 70

The values presented are to be taken as indicative and not binding; they refer to the standard equipment

TSR 30
(1) Value referred to fork dimension
l = 1120 x 570 mm

(2)Fork length available as option
L= 960 - 1190 - 1400 - 1600 -
2390 - 3590 mm
(3) With fork length l = 1000 mm

TLR 20
(1) value referred to fork dimensions
l = 1150 x 520 mm
(2) Drive wheel in rubber (standard
configuration), [drive wheel in
Vulkollan, optional]
(3) value referred to overall fork width
b5= 670 mm
(4) Fork length available as option L=

1000 - 1200 - 1400 - 1600 - 2390mm
(5) With fork length l = 1000 mm
(6) Single load wheel version,
(Tandem load wheel dimension
[option] ∅ 85 X 80)
(7) Referred to the Standard version with
Single load wheel
(N²4 with Tandem load wheels)

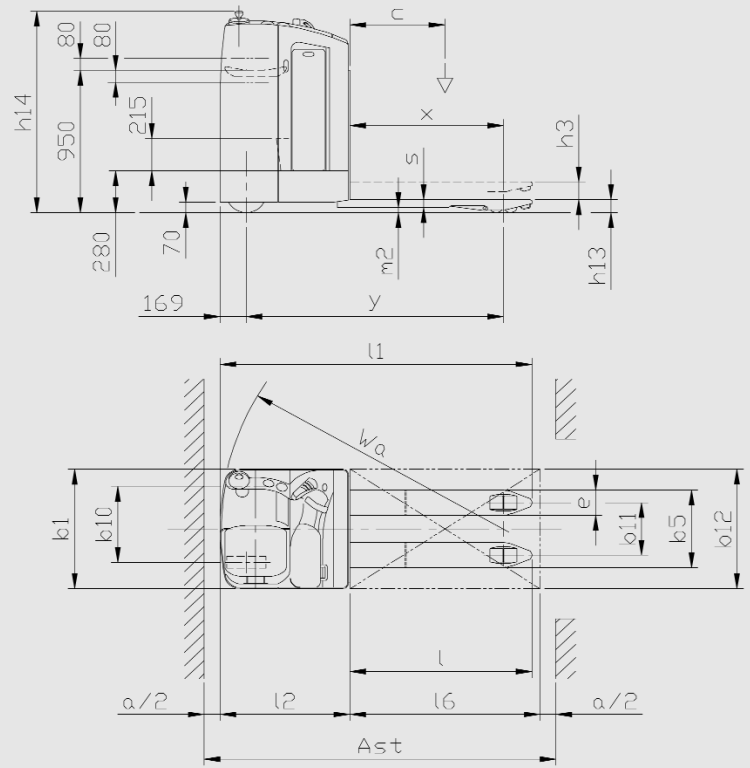
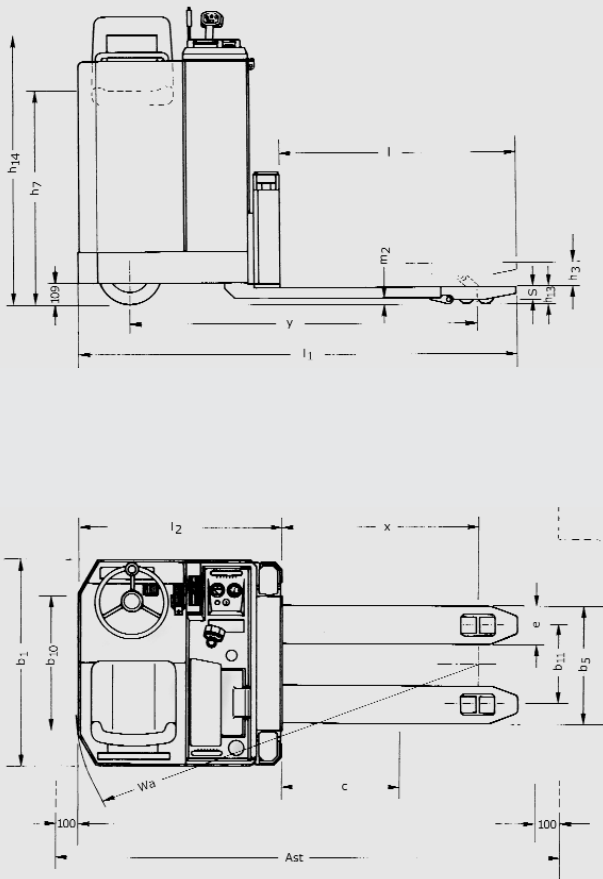

TSR								
Fork length	mm	960	1120	1190	1400	1600	2390	3590
Load center	C mm	500	600	600	700	800	1200	1800
Distance	x mm	775	935	1015	1215	1415	1850	2600
Wheelbase	Y mm	1738	1898	1978	2178	2378	2813	3563
Overall	L1 mm	2170	2330	2400	2610	2810	3600	4800

TLR								
Fork length	mm	1000	1150	1200	1400	1600	2390	
Load center	C mm	500	600	600	700	800	1200	
Distance	x mm	820	969	1020	1220	1420	1840	
Wheelbase	Y mm	1473	1623	1673	1873	2073	2493	
Overall	L1 mm	1820	1970	2020	2220	2420	3210	

TSR - TLR

Electric Rider pallet truck



TLR20



TLR20



TLR20

The TLR20 and TSR30 rider pallet trucks are built to tackle any type of transport activity even in the narrowest of spaces. The TSR30's comfortable driving position makes it the clear winner for transporting loads over long distances.

Both models offer the benefits of ergonomic operating conditions and easy maintenance.

Chassis: Robust steel construction consisting of the traction unit, which accommodates the driver's seat and all the controls, and the lift unit. Easy access to the motor for maintenance. 4-wheel structure provides optimum weight distribution and reduced pressure. Important features when using a goods lift. Pallet entry rollers under the fork tips allow for easier entry from the closed side.

Driver's seat: Spacious driver's seat designed for ergonomic operating conditions. The TLR is equipped with a small seat to allow the operator to sit down while driving if necessary. The TSR is equipped with a hydraulically cushioned seat that can be adjusted in accordance with the driver's weight and size reducing operator fatigue. Padded armrest with document holder.

Steering: Power steering with a steering wheel with spinner knob, universal joint connection and chain transmission. The small steering wheel allows for greater speed and maneuverability. The speed of the steering motor is electronically controlled by a sensor located on the universal joint that checks the rotations of the reducer.

Traction: Robust, series excited motor with forced air ventilation. High performance and optimal energy consumption due to the bevel gear transmission.

Hydraulic system: Compact but powerful pump unit operated from the control panel. The hydraulic functions are controlled by an electromagnetic valve and a valve that regulates the lower function. A pressure relief valve protects the system from becoming overloaded.

Braking: Separate service brake and parking brake. An electromagnetic brake acts as the parking brake. The truck brakes smoothly and gradually when the butterfly is operated to reverse the truck. Braking power is adjusted automatically by means of sensors in accordance with the load.

Battery: Easily accessible for maintenance. Can be removed using a battery stand.

Safety: The TSR30 and TLR20 trucks comply with the Direttiva Macchine 98/37/CEE and are CE certified.

Additional equipment: Optional fork lengths. Tandem load wheels.

Technical data are given as an indication.

OM Carrelli Elevatori reserves the right to modify them without notice.

OM Carrelli Elevatori S.p.A.
Viale A. De Gasperi, 7
I-20020 Lainate (MI)
Tel.: +39(02)937 65-1
Fax: +39(02)937 65-450
www.om-mh.com