

# CLD - CLR Technical Data



# CLD - CLR Technical Data

VDI 2198

Specification	1.1	Manufacturer		OM	OM		
	1.2	Manufacturer's model designation		CLD 20	CLR 12		
	1.3	Power supply (electric, diesel, petrol, gas, mains electric)		Electric	Electric		
	1.4	Type of control (hand, pedestrian, stand-on, rider seated, order picker)		Standing / rider seated	Standing / rider seated		
	1.5	Capacity/load	Q (t)	2 <sup>(1)</sup>	1,2		
Weights	1.6	Load centre	c (mm)	600	600		
	1.8	Load distance	x (mm)	999 / 916	690		
	1.9	Wheelbase	y (mm)	1760/1677	1450		
Wheels and Tyres	2.1	Weight (inc. battery)	kg	1390	1400		
	2.2	Axle loadings laden	drive end/load end	kg	1430 / 1970	980 / 1650	
	2.3	Axle loadings unladen	drive end/load end	kg	1010 / 380	940 / 460	
Dimensions and Overall Sizes	3.1	Tyres (rubber, Vulkollan, pneumatic, polyurethane)		Rubber	Vulkollan		
	3.2	Tyre size	drive end	mm	Ø 250 x 100	Ø 250 x 100	
	3.3	Tyre size	load end	mm	4 x Ø 85 x 60	4 x Ø 85 x 60	
	3.6	Track width	drive end	b10 (mm)	507	507	
	3.7	Trach width	load end	b11 (mm)	380	380	
	4.2	Closed mast height		h1 (mm)	1485	See mast table	
	4.4	Lift height		h3 (mm)	1590	See mast table	
Performance	4.5	Height, mast raised		h4 (mm)	2400	See mast table	
	4.6	Initial lift		h5 (mm)	120	80	
	4.9	Height of steering wheel		h14 (mm)	1345	1345	
	4.15	Forks height lowered		h13 (mm)	90	90	
	4.19	Overall length		l1 (mm)	2130	2080	
	4.20	Length to front face of forks		l2 (mm)	930	930	
	4.21	Overall width		b1 (mm)	796	796	
	4.22	Fork dimensions		s/e/l (mm)	54 / 184 / 1200	54 / 184 / 1200	
	4.24	Fork carriage width		b3 (mm)	680	680	
	4.25	Overall fork width		b5 (mm)	564	564	
	4.32	Floor clearance, centre of wheelbase		m2 (mm)	30	30	
	4.34	Working aisle width with 800 x 1200 pallet lengthwise (b12 x l6)		Ast (mm)	2577	2478	
	4.35	Outer turning radius		Wa (mm)	1930	1630	
	Engine	5.1	Speed	laden/unladen	km/h	7 / 9	7 / 9
		5.2	Lifting time	laden/unladen	m/s	0.15 / 0.23	0.17 / 0.20
5.3		Lowering time	laden/unladen	m/s	0.23 / 0.18	0.37 / 0.31	
5.8		Gradeability	laden/unladen	%	8 / 12	8 / 12	
5.9		Acceleration time (over 10 m) laden/unladen		s	7.3 / 5.6	7.3 / 5.6	
5.10		Brakes			Electric	Electric	
Others	6.1	Drive motor, rating S2 = 60 min.		kW	2.0	2.0	
	6.2	Hoist motor, rating at S3 = 15%		kW	2.0	3.0	
	6.3	Battery to IEC 254-2; A, B, C, no			IEC 254-2; A	IEC 254-2; A	
	6.4	Battery voltage, capacity K5		V / Ah	24/240 L	24/240	
	6.5	Battery weight +/- 5 % (dependent of manufacturer)		kg	370	370	
	6.6	Energy consumption according to VDI cycle		KWh/h	1.1	1.1	
Others	8.1	Drive control			Electronic	Electronic	
	8.4	Noise peak at operator's ears		dB (A)	<70	<70	

*Information and data reported here are not intended as binding in any way and refer to standard truck specification*  
For alternative masts see mast-table  
For alternative wheels see wheels-table

1) capacity on forks= 1000 kg on legs = 1000 kg  
on forks and legs overlapped 2000 kg

CLR

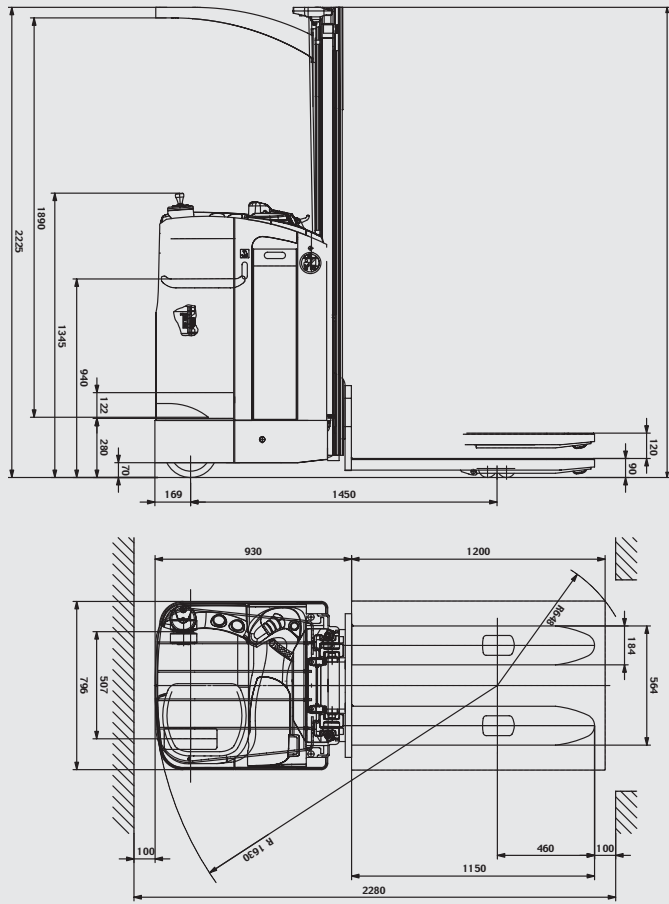

CLD

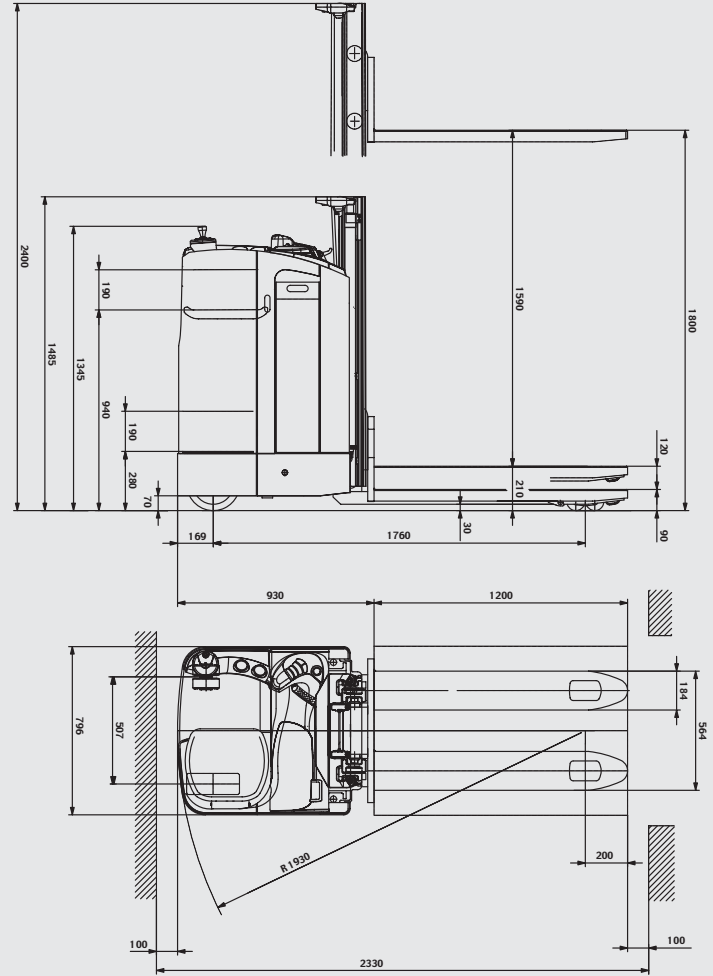

### MAST TABLE CLR

		Simplex				Duplex			
Lift height	$h_3$ mm	3445	3545	3745	4145	3445	3545	3745	4145
Height, mast lowered	$h_1$ mm	2225	2275	2375	2575	2225	2275	2375	2575
Free lift	$h_2$ mm	150	150	150	150	1690	1740	1840	2040
Height, mast extended	$h_4$ mm	3980	4080	4280	4680	3980	4080	4280	4680

### LOAD CAPACITY TABLE CLR

kg	1200	1100	1000	900	800	600	
$h_3$ mm	2700	3000	3300	3600	3900	4145	



## CLD - CLR



The CLD and CLR trucks are designed to work in any type of transport activity also when pallet stacking is needed. The CLD 20 is a stand-on double decker pallet truck, the CLR 12 is a stand-on high lift pallet truck. Both are designed for high turn around of goods.

**Driver's compartment:** Spacious driver's seat designed for ergonomic operating conditions. The CLD and CLR are equipped with a small seat to allow the operator to sit down while driving if necessary. The seat height can be adjusted in 3 positions. Padded interior is provided with storage facilities for paper and working tools. The controls are easy to handle, drive direction and travel speed are controlled by a butterfly switch with integral buttons for hoist and lowering functions. A footrest on the right side of the footwell is provided to prevent fatigue during long horizontal transport runs. Standard display shows battery discharge, operating hours and error code signals.

**Chassis:** Robust steel construction consisting of the traction unit, which accommodates the driver's seat and all the controls, and the lift unit. Easy access to the motor for maintenance. 4-wheel structure provides optimum weight distribution and reduced pressure. Automatic level compensation, on CLD20, for the load wheels makes safer transport. Skids under the fork tips make it easier to drive over thresholds and enter the pallets from the side.

**Steering:** Electric power steering with a steering wheel with spinner knob, universal joint connection and chain transmission. The small steering wheel (120mm diameter) allows greater speed and maneuverability. The speed of the steering motor is electronically controlled by a sensor located on the universal joint to keep a safe driving during curves as well.

**Drive:** A robust 2.0 kW shunt wound drive motor for quick acceleration and powerful ramp travel.

**Hydraulics:** The hydraulic unit consists of a powerful high efficiency 2.0 kW pump on CLD20 and 3.0 kW on CLR12. Fine and smooth control is achieved thanks to the proportional valve technology.

**Brakes:** Separate service brake and parking brake. An electromagnetic brake acts as the parking brake. The truck brakes smoothly and gradually when the butterfly is operated to reverse the truck. Braking power is adjusted automatically by means of sensors in accordance with the load.

**Battery:** Easily accessible for maintenance. Battery can be easily removed thanks to the patented battery free lift and a roller track at the side.

**Auxiliary equipment:** ■ Various drive wheels on CLD20 ■ Wheel position indicator

**Safety:** The CLD 20 and CLR 12 trucks comply with the Direttiva Macchine 98/37/CEE and are CE certified.

Technical data are given as an indication.

OM Carrelli Elevatori reserves the right to modify them without notice.



OM Carrelli Elevatori S.p.A.  
Viale A. De Gasperi, 7  
I-20020 Lainate (MI)  
Tel.: +39(02)937 65-1  
Fax: +39(02)937 65-450  
[www.om-mh.com](http://www.om-mh.com)