

TL - TN Technical Data



TL - TN Technical Data

VDI 2198

Specification	1.1	Manufacturer		OM	OM	OM	OM
	1.2	Model designation		TL 18	TL 20	TN 22	TN 30
	1.3	Power: battery, diesel, LPG, electric mains		Electric	Electric	Electric	Electric
	1.4	Operation: manual, pedestrian, stand.on, seated, orderpicker		Pedestrian	Pedestrian	Pedestrian	Pedestrian
	1.5	Load capacity	Q (t)	1,8	2	2,2	3
	1.6	Load centre	c (mm)	600 ⁽¹⁾	600 ⁽¹⁾	600 ⁽¹⁾	600 ⁽¹⁾
	1.8	Load distance	x (mm)	872	872	872	872
	1.9	Wheelbase	y (mm)	1239 ⁽²⁾ 1306 ⁽³⁾	1306	1347 1419	1347 1419
Weights	2.1	Unladen weight	kg	273 283	286	329 338	354 363
	2.2	Axle loading with load (front/rear)	kg	702/1495 ⁽⁴⁾ 707/1526 ⁽⁵⁾	748 / 1688 ⁽⁵⁾	854/1887 890/1936 (860/1889) ⁽⁹⁾ (903 / 1940) ⁽¹⁰⁾	1037/2529 1065/2586 (1043/2531) ⁽⁹⁾ (1077/2591) ⁽¹⁰⁾
	2.3	Axle loading without load (front/rear)	kg	308/89 ⁽⁴⁾ 332/100 ⁽⁵⁾	332 / 104 ⁽⁵⁾	411 / 130 469 / 157 (417 / 132) ⁽⁹⁾ (482 / 161) ⁽¹⁰⁾	432 / 134 490 / 161 (438 / 136) ⁽⁹⁾ (503 / 165) ⁽¹⁰⁾
Wheels and Tyres	3.1	Tyres Rubber, Pneumatic shaped solid, Pneumatic, Polyurethane	mm	Polyurethane	Polyurethane	Polyurethane	Polyurethane
	3.2	Tyre size, front	mm	230 / 100	230 / 100	250 / 100	250 / 100
	3.3	Tyre size, rear		85 X 90	85 X 90	85 X 90	85 X 70
	3.5	Wheels, number front/rear (x = driven)	b11 (mm)	1x-2 / 2	1x-2 / 2	1x-2 / 2	1x-2 / 4
Dimensions and Overall Sizes	3.7	Track width, rear	h3 (mm)	358 / 398 / 488	358 / 398 / 488	358 / 398 / 488	358 / 398 / 488
	4.4	Lift height	h14 (mm)	135	135	135	135
	4.9	Height of tiller arm in working position min./max.	h13 (mm)	762 / 1232	762 / 1232	1183 / 1380	1183 / 1380
	4.15	Lowered height	l1 (mm)	85	85	85	85
	4.19	Overall length	l2 (mm)	1693 1760	1760	1819 1891	1819 1891
	4.20	Length to face of forks	b1 (mm)	543 610	610	671 743	671 743
	4.21	Overall width	s/e/l (mm)	710	710	710	710
	4.22	Fork dimensions	b5 (mm)	50 / 162 / 1150 ⁽⁶⁾	50 / 162 / 1150 ⁽⁶⁾	50 / 162 / 1150 ⁽⁶⁾	50 / 162 / 1150 ⁽⁶⁾
	4.25	Outside fork width	m2 (mm)	520 / 560 / 650	520 / 560 / 650	520 / 560 / 650	520 / 560 / 650
	4.32	Ground clearance centre of wheelbase	Ast3 (mm)	168	168	168	168
Performance	4.33	Aisle width with pallets 1000 x 1200 crossways	Ast3 (mm)	1791 1858	1858	1912 ⁽⁸⁾ 1984 ⁽⁸⁾	1912 ⁽⁸⁾ 1984 ⁽⁸⁾
	4.34	Aisle width with pallets 800 x 1200 lengthwise	Wa (mm)	1991 2058	2058	2112 2184	2112 2184
	4.35	Turning radius	km/h	1464 1531	1531	1584 1656	1584 1656
	5.1	Travel speed with/without load	m/s	6 / 6	6 / 6	5,5 / 6	6/6
	5.2	Lift speed with/without load	m/s	0,034 / 0,045	0,034 / 0,045	0,033 / 0,076	0,03 / 0,076
	5.3	Lowering speed with/without load	%	0,045 / 0,045	0,045 / 0,045	0,045	0,045
	5.7	Gradeability KB 30' (with/without load)	%	0,9 / 19 ⁽⁴⁾ 0,8 / 17 ⁽⁵⁾	0,5 / 17 ⁽⁵⁾	-	-
5.8	Max. gradeability KB 5' (with/without load)		5,3 / 21 ⁽⁷⁾⁽⁴⁾ 5,0 / 21 ⁽⁷⁾⁽⁵⁾	4,5 / 21 ⁽⁵⁾⁽⁷⁾	-	-	
5.10	Service brake	kW	Electric at butterfly release	Electric at butterfly release	Electric at butterfly release	Electric at butterfly release	
Engine	6.1	Drive motor, S2 60 minute rating	kW	1	1	1,2	2,5
	6.2	Lifting motor, S3 15% rating		1,2	1,2	2,2	2,2
	6.3	Battery DIN 43531/35/36 A, B, C, no	V / Ah	British Standard DIN 43535 B	DIN 43535 B	DIN 43535 B	DIN 43535 B
	6.4	Battery voltage/capacity at 5 hour rate	kg	24/110(150) 24/160(220-250)	24 / 160 (220 - 250)	24 / 220 (250) 24 / 330 (375)	24 / 220 (250) 24 / 330 (375)
	6.5	Battery weight		123 (152) 150 (212 - 217)	150 (212 - 217)	212 (220) 288 (305)	212 (220) 288 (305)
Others	8.1	Drive control	dB (A)	Eletronic	Eletronic	Eletronic	Eletronic
	8.4	Average noise label, driver's ear		< 70	< 70	< 70	< 70

The values presented are to be taken as indicative and not binding; they refer to the standard equipment

(1) Values referred to fork length l = 1150 mm
 (2) With British Standard battery
 (3) With DIN Standard battery 24 V / 220 Ah (250 Ah)
 (4) With 24 V / 110 Ah battery
 (5) With 24 V / 160 Ah battery

(6) Refer to enclosed table for different fork length
 (7) Max gradeability value referred to truck design with forks lifted without load
 (8) With forks l = 980 mm
 (9) With DIN standard 24 V / 220 Ah (250 Ah) battery
 (10) With DIN standard 24 V / 330 Ah (375 Ah) battery

1= Travel
2= Braking

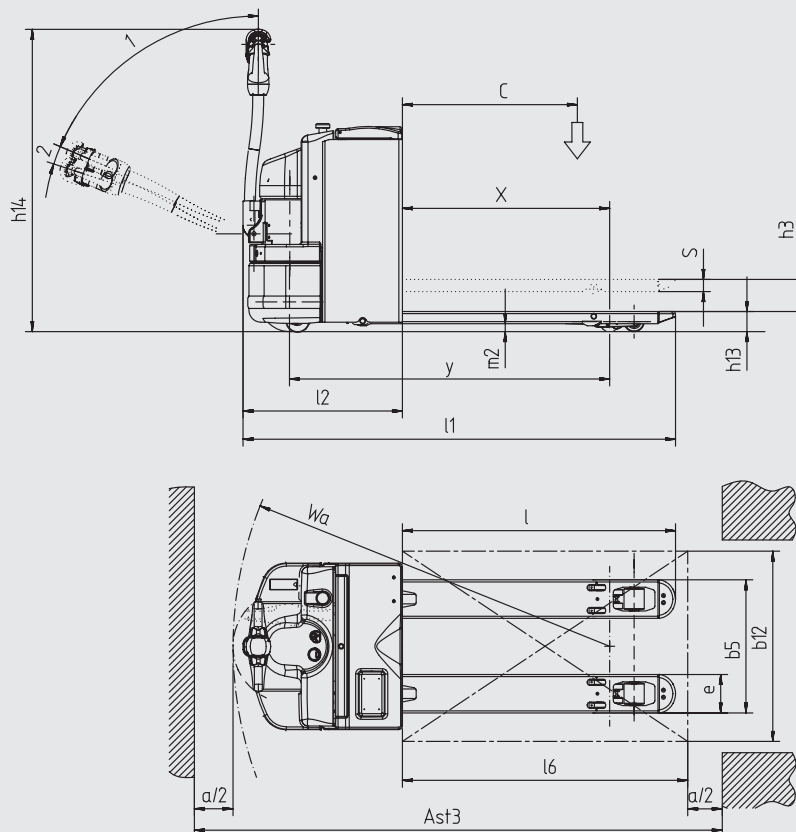

TL									
Fork			British Standard battery				DIN Standard battery		
l mm	c mm	x mm	y mm	l_1 mm	W_a mm	y mm	l_1 mm	W_a mm	
800	400	521	889	1343	1114	956	1410	1181	
980	500	701	1069	1523	1294	1136	1590	1361	
1150	600	871	1239	1693	1464	1306	1760	1531	
1450	715	1171	1539	1993	1764	1606	2060	1831	
1600	800	1321	1689	2143	1914	1756	2210	1981	

TN									
Fork			British Standard battery				DIN Large battery		
l mm	c mm	x mm	y mm	Open platform		y mm	Open platform		
				l_1 mm	W_a^* mm		l_1 mm	W_a^* mm	
800	400	522	997	1469	1234	1069	1541	1306	
980	500	702	1177	1649	1414	1249	1721	1486	
1150	600	872	1347	1819	1584	1419	1891	1656	
1450	715	1172	1647	2119	1884	1719	2191	1956	
1600	800	1322	1797	2269	2034	1869	2341	2106	
1980	1000	1702	2177	2649	2414	2249	2721	2486	
1980 pc	1000	1354	1829	2649	2066	1901	2721	2138	
2160	1072,5	1882	2357	2829	2594	2429	2901	2666	
2160 pc	1072,5	1534	2009	2829	2246	2081	2901	2318	
2400	1200	2122	2597	3069	2834	2669	3141	2906	
2400 pc	1200	1774	2249	3069	2486	2321	3141	2558	

* Based on tiller in vertical position (Tiller active in vertical position)

TL - TN

Pedestrian low lift pallet trucks



Pedestrian low lift power pallet trucks TL and TN The model range: includes the TL for standard and the TN for heavy-duty applications with capacities from 1800 up to 3000 kg.

Chassis: ■ The battery compartment is thoroughly enclosed within the chassis protecting the DIN and BS standard batteries. Batteries are removed from the top but as an option side removal is available. ■ The forks are manufactured of high resistance Domex steel. ■ The paint is applied by the most advanced painting technology available. All non-painted components are treated for corrosion protection. ■ The strong polyethylene bonnets are both resistant and flexible so as to absorb shocks without deformation.

Tiller: ■ The welded tiller arm is oval to increase strength incorporating a new concept handle in high resistance plastic. ■ The unique tiller shape and joint enables all operators to assume the most comfortable operating position independently of stature. ■ The lightweight tiller is user friendly enabling continuous use and ensuring minimum operator fatigue. On release the tiller returns to the upright position in a steady, controlled manner. A standard feature of these models is the ability to drive the truck with the tiller in the upright position at reduced speed in confined spaces.

Drive: ■ Reliable and powerful motors incorporating separate excitation start from 1 kW up to 2.5 kW (for TN30), ensuring equal performance both laden and unladen. ■ The JULI motors require brushes on average only after 5000 operation hours.

Electronic system: ■ The power supply is 24V DC. ■ Traction and lift electronics are enclosed in one static high frequency control unit with MOSFET type transistors. ■ The electronics incorporate a regenerative braking system thus allowing energy recovery on release of the accelerator. ■ The service meter is dual-purpose and is also used for fault detection. ■ The new electronic control systems are not only silent but reduce overall power consumption, increasing battery life. The system constantly monitors the functions of the pallet truck, protecting against power surge and damage to the battery.

■ All electrical systems and wiring are produced to IP54 standard and protected against water spray and dust infiltration, giving increased reliability. Saab electrical connections incorporated in the wiring have increased protection to IP67 standard.

Braking system: Two different braking modes are incorporated as standard: ■ reverse current braking (re-generative) ■ automatic electromagnetic parking brake with inductive sensors on the tiller at both stop positions.

Maintenance: ■ Readily accessible lifting points facilitate battery installation and removal operations. ■ OM staff can reprogram all the acceleration, braking and speed parameters via the electronic control system. ■ The first service is due at 600 operational hours, except for those components stated otherwise.

Technical data are given as an indication.

OM Carrelli Elevatori reserves the right to modify them without notice.



OM Carrelli Elevatori S.p.A.
Viale A. De Gasperi, 7
I-20020 Lainate (MI)
Tel.: +39(02)937 65-1
Fax: +39(02)937 65-450
www.om-mh.com